

## FACTORY INSTALLED FRAMING OPTIONS

Da-Lite offers optional frames that not only protect the screen but are professional, good looking and allow for easy installation.

### Deluxe Frame

- Impressive architectural design adds sophistication to any installation.
- 1-3/4" x 3" rectangular base tube.
- Dovetail frame eliminates light leakage.
- Black anodized finish.
- Frame insert size equals screen viewing area plus 5-1/2".

### Deluxe Frame

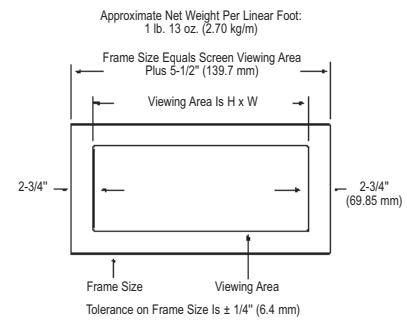
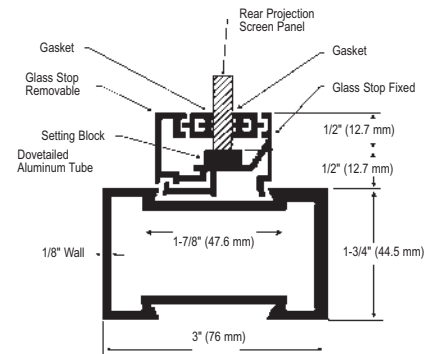

### Standard Frame

- Same great features as the deluxe frame but 1" x 1-3/4" base tube.
- Dovetail frame eliminates light leakage.
- For screen panels up to 6' x 10'.
- Black anodized finish.
- Frame insert size equals screen viewing area plus 4".

### Standard Frame

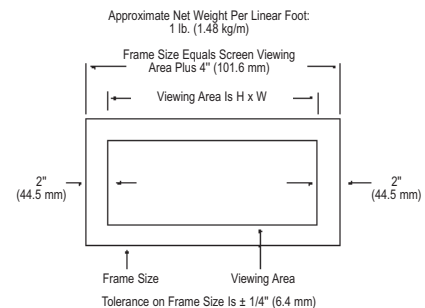
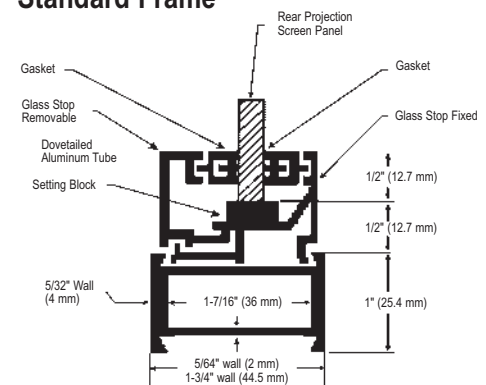

**FACTORY INSTALLED FRAMING OPTIONS**

**Self-Trimming Frame**

- Eliminates the need for finish trim for fast, easy installation.
- Built-in 1-1/2" wide molding to hide opening.
- Black anodized finish.
- Frame insert size equals screen viewing area plus 2-7/8".

**Self-Trimming Frame**

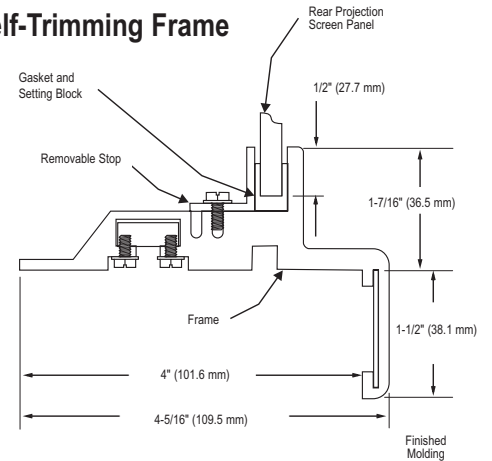

Approximate Net Weight Per Linear Foot:  
2 lbs. 8 oz. (3.7 kg/m)

Frame Trim Size Equals Frame Insert Size Plus 3" (76.2 mm), or Screen Viewing Area Plus 5-7/8" (149.2 mm)

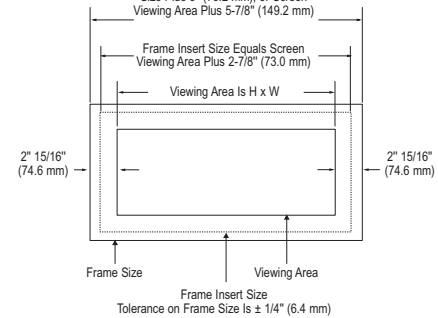

**Base Frame**

- Mitered corners eliminate rear light leaks without caulking.
- Black anodized finish.
- Constructed of lightweight extruded aluminum U-channel.
- Frame dimensions equal viewing area plus 2-1/2".

**Base Frame**

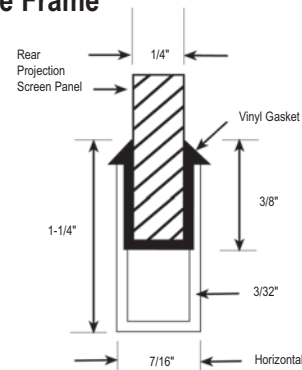

Approximate Net Weight Per Linear Foot:  
5 oz. (0.142 kg/m)

Frame Size Equals Viewing Area Plus 2-1/2" (63.5 mm)

